

Trumatic E 2400 (Australia)

AUS **Operating instructions**
Installation instructions

To be kept in the vehicle!

Page 4

Page 7

Table of contents

Installation example	2	Installation instructions	
Symbols used	3	Intended use	7
Safety instructions	3	Approval	7
Important operating notes	3	Regulations	7
Operating instructions		Choice of location	7
Control panel with rotary switch	4	Exhaust duct	8
Switching on the Heating	4	Permissible duct lengths	8
Switching on the Ventilation	4	Interior installation using the wall cowl kit	8
Switching off	4	Assembly of wall cowl	8
Green LED "Operation"	4	Fastening the appliance	8
Fuses	4	Double cowl duct connection to the heating appliance	8
Red LED "Failure"	4	Warm air distribution and circulating air return with interior installation	9
Maintenance	4	Warm air distribution	9
Accessories	4	Circulating air return	9
Technical data	5	Fitting the control panel	9
Dimensions	5	Installing the control panel with rotary switch	9
Truma warranty policy	5	Fitting the electronic control units	10
Trouble-shooting list	6	Electrical connection 12 V	10
		Gas connection	10
		Function check	11
		Warning information	11

Installation example

- 1 Control panel
- 2 Time switch (accessories)
- 3 Combustion air
- 4 Flue gas
- 5 Electronic control units
- 6 Power supply
- 7 Gas connection
- W Warm air
- U Circulating air

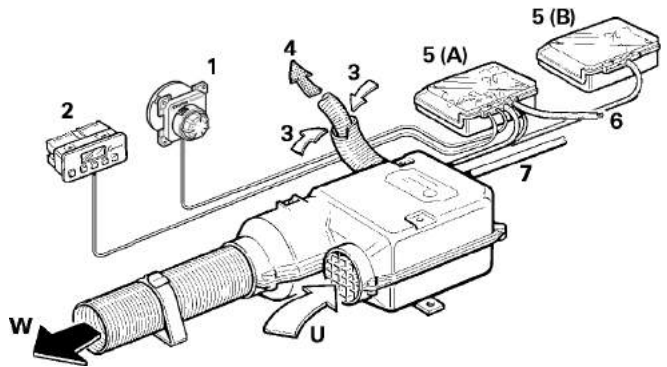

Installation options

1

Installation inside the vehicle with wall flue kit



This symbol indicates possible hazards.



Information and advice.

Safety instructions

The use of upright gas cylinders from which gas is **taken in the gas phase** is mandatory for the operation of gas regulators, gas equipment and gas systems. Gas cylinders from which gas is taken in the liquid phase (e.g. for fork lifts) must not be used, since they would result in damage to the gas system.

If the gas system is leaking or if there is a smell of gas:

- extinguish all flames
- do not smoke
- switch off the appliances
- shut off the gas cylinder
- open windows and door
- do not actuate any electrical switches
- have the entire system checked by an expert!



Repairs may only be carried out by an expert!

A new O-ring must always be installed after dismantling the exhaust duct!

Guarantee claims, warranty claims and acceptance of liability will be ruled out in the event of the following:

- modifications to the unit (including accessories),
- modifications to the exhaust duct and the cowl,
- failure to use original Truma parts as replacement parts and accessories,
- failure to follow the installation and operating instructions.

It also becomes illegal to use the appliance, and in some countries this even makes it illegal to use the vehicle.

The gas supply's operating pressure (2.75 kPa) must be the same as the unit's operating pressure (see type plate).

LPG Systems and pressure regulators must comply with the technical and administrative regulations of the country in which the appliance is used. For your own safety it is absolutely necessary to have the complete gas installation regularly checked by an expert (at least every 2 years).

The vehicle owner is always responsible for arranging the gas inspection.

Pressure regulating equipment and hoses must be replaced with new ones no more than 10 years after the date of manufacture. This is the responsibility of the operator.

Liquid gas equipment must not be used when refuelling, in multi-storey car parks, in garages or on ferries.

During the initial operation of a brand new appliance (or after it has not been used for some time), a slight amount of fumes and smell may be noticed for a short while.

This will be remedied by running the heater and ensuring adequate room ventilation.

If the burner makes an unusual noise, it is likely that the gas pressure regulator is faulty and it is essential to have it checked.

Do not place articles on or against this appliance.

Do not use or store flammable materials near this appliance.

Do not spray aerosols in the vicinity of this appliance while it is in operation.

livery pressure of 2.75 kPa may be used.

The flow rate of the pressure control device must correspond to at least the maximum consumption of all devices installed by the system manufacturer.

Controller connecting hoses that meet national regulations must always be used in the respective country for which the equipment is destined. These hoses must be checked regularly for brittleness. Winter-proof special hoses must always be used if the equipment is operated during the winter.

Important operating notes

The integrity and tight fit of the exhaust gas double duct must be checked regularly, particularly at the end of long trips. Also check the mounting of the appliance and the cowl.

Following a blow-back (misfire) always have the exhaust gas system checked by an expert!

Always keep the cowl for conducting exhaust gas and supplying combustion air, free from contamination (slush, leaves etc.).

The installed temperature limiter shuts off the gas supply if the appliance becomes too hot. Therefore do not shut the warm air outlets and the opening for the returning circulating air.

The cabin air flow through the heater must not be restricted in any way. Do not use any after market air filters or air grills. The use of such components may cause the unit to over heat.

Warning: Air from the discharge vent may be hot. Do not place combustible materials directly in front of the discharge vent. Keep curtains, bedding and other flammable materials away from the vent.

Always use original Truma parts for maintenance and repair work!

Operating instructions

Always observe the operating instructions and "Important operating notes" prior to starting! The vehicle owner is responsible for the correct operation of the appliance!

The installer or vehicle owner must apply the yellow sticker with the warning information, which is enclosed with the appliance, to a place in the vehicle where it is clearly visible to all users (e.g. on the wardrobe door)! Ask Truma to send you stickers, if necessary.

Control panel with rotary switch

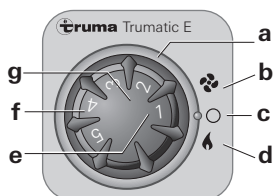

- a = rotary switch (external ring)
- b = "Ventilation" rotary switch
- c = "Off" rotary switch
- d = "Heating" rotary switch
- e = green LED lit "Operation"
- f = rotary knob for room temperature (1 – 5, 4 ≈ 23 °C)
- g = red LED lit, red LED blinking "Failure"

Switching on the Heating

Turn on gas cylinder and open quick-acting valve in the gas supply line.

Adjust desired room temperature at rotary knob.

Switching the heating on:
Set the rotary switch to (d).

Switching on the Ventilation

Set the rotary switch to (b).

Switching off

Set the rotary switch (a) to the centre (c). If the appliance is switched off after a heating phase, the fan can continue running in order to make use of the residual heat.

If the appliance is not used for a prolonged period of time, close quick-acting valve in the gas supply line and turn off gas cylinder.

Green LED "Operation"

(under rotary control knob)

When the appliance is switched on (heating or ventilation) the green LED must be illuminated (the fan is running). If the LED is **not** illuminated, possibly check the (main) switch. For this purpose observe respective instructions of the vehicle manufacturer.

During the heating operation, while the flame is burning, the green LED lights up with twice the intensity. This also makes it possible to determine the instantaneous switching point of the room temperature.

The device and control panel fuses are on the electronic control unit on the device.

Device fuse (F1):
3.15 AT – slow –

Control panel fuse (F3):
1.6 AT – slow –

The fine-wire fuse must only be replaced by a fuse of the same design.

Red LED "Failure"

Should a failure occur, the red LED is illuminated **permanently**. Possible causes for the failure can be e.g. no gas, insufficient combustion air, heavily soiled fan, defective fuse etc.. Deactivate by switching off and then switching on again.

Flash operation indicates that the operating voltage is too low (charge battery, if necessary) or too high for the appliance.

Maintenance

The unit must be checked annually for contamination (dust, dirt, debris) by an expert and cleaned if necessary.

 Servicing shall be carried out only by authorised personnel.

Please contact Dometic Service Centre for service and repairs.

Accessories

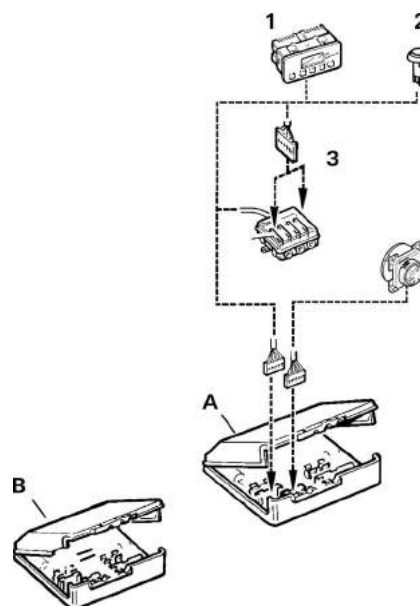

1 Time switch ZUE 2

for pre-programming 3 switch-on times within 7 days, including 4 m connecting cable (suitable for 12 V vehicle electrical system).

2 Remote sensor FFC 2

monitors the room temperature independent of the position of the control panel (with 4 m connecting cable).

3 Multiple box MSD

for connecting several accessories (e.g. time switch and remote sensor).

Extension cable for accessories

items 1, 3 of 4 m or 10 m (not illustrated).

All electrical accessories are fitted with a connector and can

determined in accordance with AS 4556/2000 or Truma test conditions

Manufacturer

Truma Gerätetechnik GmbH & Co. KG
P.O. Box 1252
85637 Putzbrunn / Munich
Germany

Type of gas

LPG (propane)

Test point pressure

2.75 kPa (see type plate)

Nominal input

8.56 MJ/h

Gas consumption

170 g/h

Air flow rate

Approx. 78 m³/h

Power consumption 12 V

1.1 A

Standby

0.01 A

Weight

Heater unit (without control devices)	5.0 kg
Heater unit with peripheral devices (without cowl kit)	6.0 kg
Cowl kit	0.7 kg

Declaration of conformity

The heater E 2400 (Australia) is tested and approved according AS 4556/2000 and fulfils the standard.

The heater complies with the interference suppression directive 72/245/EEC for vehicle engines with annexes 2004/104/EC, 2005/83/EC and 2006/28/EC.

AGA approval number

7550



The right to effect technical modifications is reserved!

Dimensions

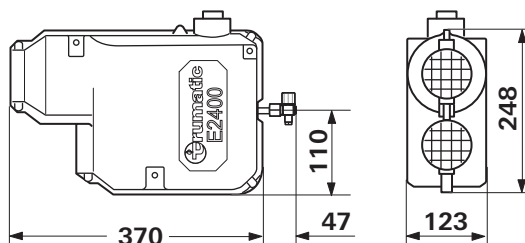

All dimensions in mm.

The warranty is given by Dometic Pty Ltd, Building 3B, Clayton Business Park, 1508 Centre Road, Clayton, Victoria, 3168, for 12 months from the date of purchase against any defect arising from faulty materials or workmanship.

Repairs will be carried out during normal business hours only by Dometic Pty Ltd, or its duly authorised service agents, and are subject to the warranty conditions and exclusions hereunder.

Warranty conditions

- The company will only provide service on presentation of proof of purchase, on either the Truma product, or the Caravan / RV / Pleasure Craft in which the Truma product has been installed, to any authorised service agent. The purchaser must allow the service agent to photocopy the proof of purchase to facilitate his claim to the manufacturer.
- Warranty repairs can only be performed by authorised service agents and under no circumstances will Dometic reimburse repairs carried out by unauthorised persons. Tampering with any part of the product by unauthorised personnel will automatically void the warranty.
- The product must be used solely for domestic purposes only. If the product is used for commercial purposes the warranty is 6 months only.
- Where applicable, the products must be used on the appropriate electrical voltage, gas type and pressure, or fuel source.
- If at any time during the warranty period any part or parts are replaced with a part or parts not supplied or approved by Truma, this warranty shall immediately become void.

Important notice

Before calling a service technician please check carefully the operating instructions, warranty terms and conditions. If the product fails for any of the reasons detailed therein, or is faulty due to abuse, misuse or improper installation, then a service fee shall be charged to the purchaser.

If you have any queries regarding the interpretation of the warranty you should contact Dometic Pty Ltd.

Whilst this book represents service outlets at the time of printing, changes occur from time to time. Should you have any queries or wish to locate your nearest authorised service agent please contact Dometic Pty Ltd.

Warranty does not cover

- Any heater which has been:
 - (a) Subject to misuse, neglect, accident or alteration by any person.
 - (b) Damaged or destroyed by fire, flood, act of God or other inevitable accident.
- Fair wear and tear.
- Damage from foreign substances such as dirt or liquid.
- Travelling expenses or call out fee to and from authorised service agents premises.
- Accommodation or Site Expenses.
- Cleaning of the system or cleaning and adjustment of the gas system. This is considered to be a part of normal product maintenance.
- Non operation of the heater or resultant damage to the unit where the heater has been operated in an out of level situation.
- Freight cost of the appliance or parts, to or from, point of service or transit damage.
- Dometic / Truma are not responsible for resultant loss or damage sustained by the purchaser.
- Non operation of the appliance or resultant damage to the unit where the appliance has not been installed, ventilated, flued or operated in accordance with the manufacturers instructions.

Apart from any warranties implied by the Trade Practices Act 1974 or any relevant State legislation all other warranties express or implied whether arising by virtue of statute or otherwise are hereby excluded.

Fault	Cause	Rectification
After switching on none of the LEDs are lit.	– No operating voltage.	– Check 12 V battery voltage, charge if necessary. – Check all electrical plug connections.
	– Device fuse or vehicle fuse defective.	– Check the unit or vehicle fuse and replace if necessary (see fuses).
The green LED comes on when the unit is switched on but the heater does not operate.	– The temperature setting on the control panel is lower than the room temperature.	– Select higher room temperature at the control panel.
Red LED flashes 1 x per sec.	– Under-voltage range 10.9 V – 10.5 V.	– Charge battery!
Red LED flashes 3 x per sec.	– Over-voltage range 15.8 V – 16.4 V.	– Check the battery voltage and power supply such as e.g. the charging device.
Approximately 30 seconds after the heater is switched on, the red LED is lit.	– Gas cylinder or quick-acting valve in the gas line is closed.	– Check gas supply and open valves.
	– Combustion air infeed or exhaust outlet is sealed.	– Remove cowl cap. – Inspect openings for contamination (slush, ice, leaves, etc.) and remove contamination if necessary.
After operating for a longer period of time, the heater switches to failure.	– Hot-air outlets blocked.	– Check individual outlet apertures.
	– Recirculated air intake blocked.	– Remove blockage from recirculated air intake.
	– Gas pressure regulator iced up.	– Use regulator heating (EisEx).

If these measures do not remove the failure, please contact the nearest Dometic Service.

This appliance must be installed by an authorised person.



Non-compliance with installation instructions or incorrect installation can result in endangerment of persons and property.

This appliance shall be installed in accordance with the manufacturer's installation instructions, local gas fitting regulations, municipal building codes, electrical wiring regulations, AS 5601/2004 "Gas Installations", and any other statutory regulations.

Intended use

This device was designed for installing in vehicles (motor homes and caravans). Other applications are also possible following consultation with Truma.

Vehicles for hazardous materials

Combustion heaters for gaseous fuel are not permitted.

Approval

Declaration of conformity

The heater E 2400 (Australia) is tested and approved according AS 4556/2000 and fulfils the standard.

The heater complies with the interference suppression directive 72/245/EEC for vehicle engines with annexes 2004/104/EC, 2005/83/EC and 2006/28/EC.

AGA approval number

7550



The year when the equipment was first taken into operation must be indicated with a check on the type plate.

Regulations

Guarantee claims, warranty claims and acceptance of liability will be ruled out in the event of the following:

- modifications to the unit (including accessories),
- modifications to the exhaust duct and the cowl,
- failure to use original Truma parts as replacement parts and accessories,
- failure to follow the installation and operating instructions.

It also becomes illegal to use the appliance, and in some countries this even makes it illegal to use the vehicle.

In-vehicle installations must comply with the technical and administrative regulations of the respective country of use (e.g. AS 5601/2004 for vehicles). The national regulations and rules must be complied with.

In other countries always observe the respectively valid regulations.

For further details on the rules and regulations in the respective country of designation, please contact our agencies abroad (see www.truma.com).

Always install the appliance and its exhaust duct in such a way that it is always easily accessible for service work and can be removed and installed easily.

This appliance can be installed without any clearance to combustible materials providing the surrounding materials will withstand temperatures of up to 85 °C. The flue and warm air ducts can also be installed without clearance providing only Truma components supplied with the appliance are fitted. Make sure that there is at least 10 mm clearance to combustible materials around the warm air discharge vent and 500 mm in front of the vent. Locate the vent so that curtains, bedding, etc. cannot be blown directly in front of or in contact with the warm air vent.

Steps must be taken to ensure that the warm air outlet of the heating system is never obstructed (see warm air distribution).

The installation space must have appropriate openings for the circulating air return (see circulating air return).

Locate the heater in such a way that the cowl can be mounted on the outside on a surface which is as straight and smooth as possible.

For evenly distributed heating, the installation of the appliance should be as much in the **centre** of the vehicle as possible, and in such a way that the air distribution ducts can be routed with approximately the same length.

The cowl must be placed in such a way that the exhaust gas cannot find its way into the vehicle interior. **The exhaust gas cowl can only be installed through a vertical wall to the outside, never through a horizontal surface.**



The flue cowl must always vent to outdoors and not into any annex or other enclosed area.

This outside surface must be exposed to wind from all directions and, if possible, there should be no trim strips or covers in this area, mount heater on an appropriate base, if necessary.

The wall cowl is to be fitted in such a way that no tank nozzles or tank ventilation apertures are located within 500 mm (R) of it. In addition, no air discharge apertures for the living area or window openings may be located with 300 mm of it.

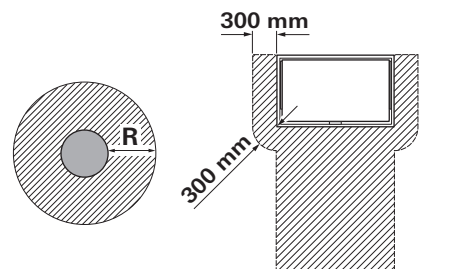

If installing the cowl directly underneath a window that will be opened, installation of an electric window switch (part no. 34000-85800) is mandatory. The gas unit must automatically switch itself off using the Truma automatic shut-off facility if the window is opened (Accessories, part no. 39050-00800).

Refer to AS 5601/2004 – Gas Installations, for location requirements of the flue terminal.

With the Trumatic E 2400 (Australia) only use the Truma exhaust duct AA 24 (part no. 39420-00) with wall cowl and the combustion air supply duct ZR 24 (part no. 39440-00) for the installation, as the appliance has only been tested and approved with these ducts.

 A new O-ring must always be installed after dismantling the exhaust duct!

Permissible duct lengths

Interior installation with wall cowl

(refer to installation variant 1, page 2):

– **Duct lengths of up to max. 70 cm** can be routed as ascending duct in any way required, or descending by max. 30 cm.

– **Duct lengths from 30 cm to max. 100 cm** must be routed as ascending duct with an ascending angle of min. 45°.

Interior installation using the wall cowl kit

Refer to installation variant, Fig 1 (page 2).

Assembly of wall cowl

Assemble wall cowl on a surface which is as flat as possible and which is exposed to wind from all directions. Drill an opening (8) measuring 70 mm in diameter (pack wood into hollow spaces in the area of the cowl opening). Use the provided rubber seal (10) for sealing. In the event of structured surfaces, coat with plastic body sealant – do not use silicone.

In the event of a greater wall thickness, first connect the exhaust double duct to the cowl from the outside.

Slide rubber seal (10) and clamp (4) onto the cowl inner part (11).

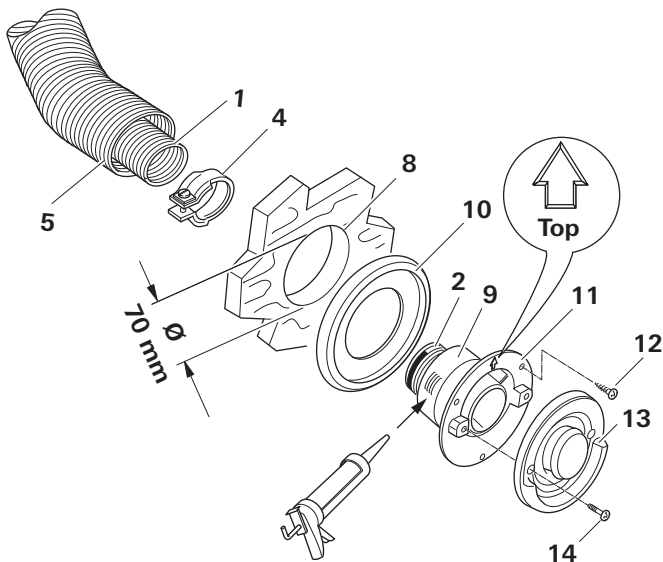

width of the clamp (4) as shown in the diagram below. Slide exhaust duct over the O-Ring (2a) on the flue cowl connection fitting (2) up to the collar (3). Make sure the flue cowl bend points upwards. Ensure the edge of the clamp (4) fits over the collar (3). Tighten the clamp (4) over the collar (3) and the compressed corrugations of the exhaust duct (1) as shown in the diagram below.

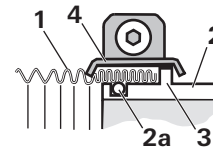

Coat serrated connection fitting (9) with plastic body sealant – do not use silicone! – and slide over combustion air supply duct (5).

Fasten cowl inner part (11) with 3 screws (12 – observe installation position! Mount cowl outer part (13) and screw on with 2 screws (14).

 Always install a new O-ring following any disassembly!

Fastening the appliance

Depending on the installation position, bolt on the appliance using fastening strap (a) or mounting brackets (b). Fasten exhaust double duct to the wall using duct clamp ZR 24 (c), if necessary (in the scope of delivery).

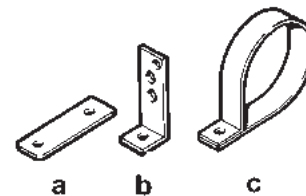

Double cowl duct connection to the heating appliance

Compress the corrugations of the exhaust duct (1) for the full width of the clamp (4) as shown in the diagram below. Slide exhaust duct over the O-Ring (2b) on the heater connection fitting (2) up to the collar (3). Ensure the edge of the clamp (4) fits over the collar (3). Tighten the clamp (4) over the collar (3) and the compressed corrugations of the exhaust duct (1) as shown in the diagram below. Fasten combustion air supply duct (5) on the connection fitting (6) using clamp (7).

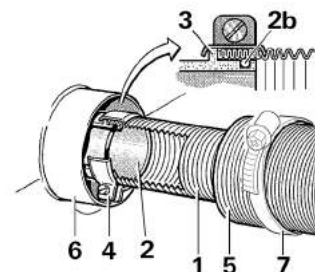

 Always install a new O-ring following any disassembly!

return with interior installation

Warm air distribution

Hot air suction apertures must be arranged in such a way that no exhaust gases from the engine or the heating device can be drawn in. It must be ensured by means of construction design that the heating air introduced into the vehicle is not polluted (e.g. by oil vapour). This is achieved, for example, with air heaters with circulating air operation.

! Only use original Truma parts for ducting, outlets, fittings and accessories, supplied by Dometic or Truma. Do not use any other parts.

The warm air (W) is blown out from the appliance, either directly or using a warm air duct VR 80 (80 mm diameter).

Remove grating from warm air outlet of the appliance. Connect duct VR 80 (80 mm diameter). By positioning a manifold section, the ducts VR 72 (72 mm diameter), ÜR (65 mm diameter) or ZR 18 (49 mm diameter) can also be added on.

Use the following table to determine the number of required air openings in the warm air duct.

Duct length*	Number of air openings
up to and including 1 m	at least 1 air opening
over 1 m up to 5 m	at least 2 air openings (the first air opening after max. 1 m)
5 m a more	at least 3 air openings (the first air opening after max. 1 m)

* In the case of duct branches, the sum of the installed warm air ducts.

! In order to avoid overheating, there must be **at least one air passage which is always open** (swivel nozzle SCW 2).

Secure all duct connections with self-tapping screws. Fasten ducts with clamps.

The hot air system is individually designed for each vehicle model using a modular principle. A wide range of accessories is available for this purpose.

Circulating air return

The circulating air (U) is sucked back into the appliance, either directly or via a duct piece VR 80 (80 mm diameter).

1. Direct intake: If the appliance is installed in a storage compartment or such, drill two holes measuring 75 mm in diameter into it, or make a corresponding opening for the circulating air return.

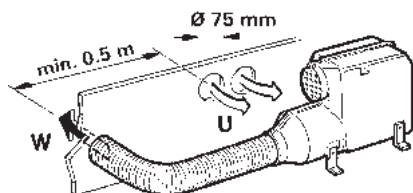

! Do not obstruct the air passage to the appliance!

2. Circulating air outside the storage area can be drawn in via a duct piece VR 80 (1) 80 mm diameter (max. 100 cm in length) and returned to the appliance. The storage compartment can then be used to the full.

Insert duct piece (1) into the grating connection fitting and fasten using the available screws. Attach swivel nozzle SCW 2 to the duct end (4).

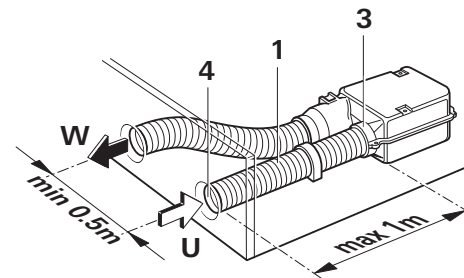

Fitting the control panel

! Any modification made to the Truma components pertaining to this will lead to the cancellation of the guarantee and to the exclusion of any claims for liability. The installer (manufacturer) is responsible for providing operating instructions for the user as well as for the labelling of the control panels!

When selecting the location, take note that the control panels must not be subjected to any direct radiant heat. Length of the connection cable 4 m or 10 m.

i Selecting the position of the thermostat is very important, the reading of the air temperature is taken by the thermostat, therefore the position of the thermostat needs to be considered. The thermostat must be placed in an area away from sunlight or any external source of heat. The position should be chosen to represent the average air temperature experienced inside the vehicle.

If installation is only possible behind curtains or in similar locations with temperature fluctuations, a remote sensor for the ambient temperature must be used (Accessories).

Installing the control panel with rotary switch

i If flush mounting is not possible, Truma will supply an on-surface frame (1 – part no. 40000-52600) as an accessory on request.

Drill a hole \varnothing 55 mm in diameter.

Plug the control panel cable (2) into the control panel (3) and then fit the rear cover cap (4) as a stress-relieving device.

Push the cable through to the rear and lay it to the electronic control unit.

Secure the control panel with four screws (5) and fit the cover frame (6) in place.

i Truma offers side parts (7) in eight different colors for finishing the cover frames (6) in a visually pleasing way. Please ask your dealer.

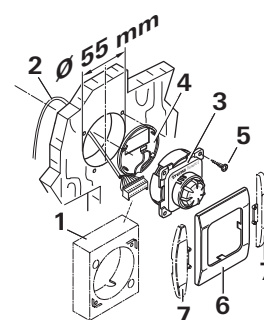

Unscrew the cover of the control units (A and B).

 The plugs on the electronic control units should only be withdrawn or plugged in if the supply voltage had been disconnected beforehand. Pull the plug out straight!

Insert the plug on the control panel cable (1) as shown in the diagram onto the red terminal strip of the control unit (A).

Insert plug (2) – 20-pin – in the grey terminal strip on the control unit (A).

Insert plug (3) – 10-pin – in the red terminal strip on the control unit (B).

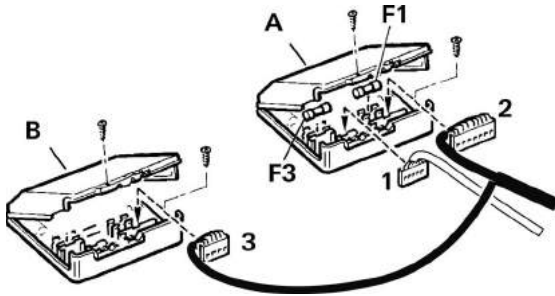

 If a timer switch or a remote sensor is fitted, its plug is to be inserted on the black terminal strip (control unit – A). If several accessory components are being used at the same time, connection is effected via the multiple box (Accessories).

Secure the lower parts with two screws at an easily accessible location, protected against moisture (must not be heated to above 65 °C).

Screw the cover of the control units into place.

Electrical connection 12 V

Electric cables, switching units and control units for heaters must be arranged in the vehicle in such a way that their satisfactory operation cannot be adversely affected under normal operating conditions. All cables leading to the outside must be splash proof at the leadthrough opening.

Prior to working on electric components the appliance must be disconnected from the power supply. Switching off at the control panel is not sufficient!

When carrying out electric welding work on the body the appliance connection must be disconnected from the vehicle electrical system.

 If the connections are transposed there is a risk of cable burning. This also rules out any guarantee or liability claims!

 The red cable is positive, the blue cable is negative!

Connect the appliance to the fused vehicle electrical system (central electrical system 5 – 10 A) using the 2 x 1.5 mm² cable, for lengths over 6 m use 2 x 2.5 mm² cable. Negative cable to central ground. For direct connection to the battery the positive and negative cable must be fused. Connections in Faston terminals, fully insulated (motor vehicle flat connector system, 6.3 mm).

Do not connect any other consumers to the supply line!

 When power packs or power supply units are being used, note that the output voltage is between 11 V and 15 V and the alternating current ripple is < 1.2 Vpp.

 The gas supply's operating pressure (2.75 kPa) must be the same as the unit's operating pressure (see type plate).

The gas inlet connection on the E 2400 (Australia) is a 8 mm connection.

The gas connection fitting on the appliance is not to be shortened or bent.

To connect, the UNF 1/2" – 20 (SAE Male AN Flare) gas inlet connection provided with the appliance must be used.

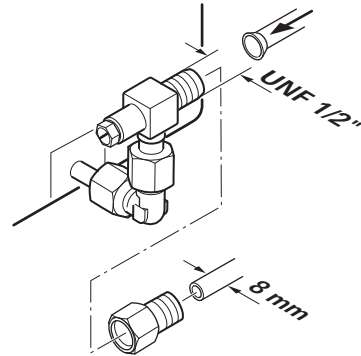

For connection to 8 mm steel piping Dometic provides an adapter UNF 1/2" x RVS 8, part no. 70020-02700.

Before connecting to the appliance make sure that the gas lines are free from dirt, chips and such!

Route the pipes in such a way that the appliance can be removed again for servicing.

Refer to AS 5601/2004 – Gas Installations, for gas pipe sizing.

The gas inlet connection is preinstalled.

Please check for leaks before starting up for the first time.

Check for gas leaks (do not check for gas leaks with a naked flame), then check that the gas pressure is as follows:

Propane gas: 2.75 kPa

Keep the number of parting connections in the gas supply line in rooms frequented by people to a technically feasible minimum.

The gas system must accord with the technical and administrative provisions of the individual country of use (in Australia, AS 5601/2004 for motor vehicles). National regulations and rulings must be respected.

After installation, check gas supply line for leaks in accordance with the pressure drop method.

Always observe the operating instructions prior to starting!

Then check all functions of the appliance, as specified in the operating instructions.

If the appliance can not be adjusted to perform correctly, please contact Dometic Service Centre.

The operating instructions and completed guarantee card are to be given to the owner of the vehicle.

 Remove the type plate from the operating and installation instructions and affix it at a position on the heater which is clearly visible and well protected against damage. The year of initial operation must be marked on the type plate.

Warning information

The installer or vehicle owner must apply the yellow sticker with the warning information, which is enclosed with the appliance, to a place in the vehicle where it is clearly visible to all users (e.g. on the wardrobe door)! Ask Dometic to send you stickers, if necessary.

if problems are encountered; in other countries the relevant service partners should be contacted (www.truma.com).

Having the equipment model and the serial number ready (see type plate) will speed up processing.

Dometic Pty Ltd
Building 3B,
Clayton Business Park
1508 Centre Road
Clayton, Victoria, 3168

Service (Australia)

Telephone: +61 (0)3 92 39 10 50

Dometic New Zealand Ltd.
Post Box 12011
1642 Penrose, Auckland

Service (New Zealand)

Telephone +64 (0)9 622 14 90