

# Combi D 6 (Australia)

**AUS** **Operating instructions**  
To be kept in the vehicle!

Page 2

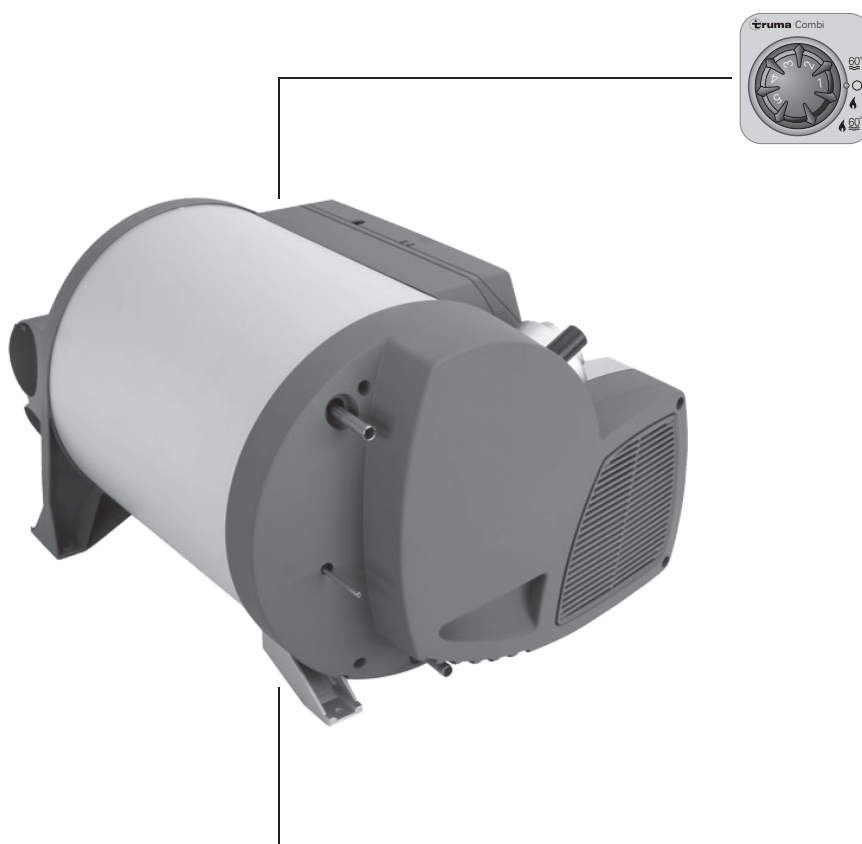

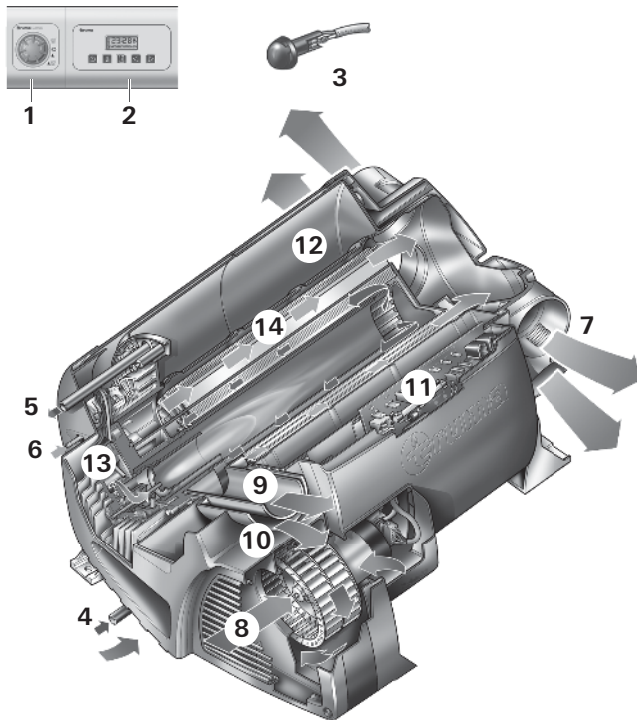

- 1 Control panel
- 2 Time switch ZUCB (Accessories)
- 3 Room temperature sensor
- 4 Cold water connection
- 5 Hot water connection
- 6 Fuel connection
- 7 Hot air outlets
- 8 Recirculated air intake
- 9 Waste gas discharge
- 10 Exhaust air flue
- 11 Electronic control unit
- 12 Water container (10 litres)
- 13 Burner
- 14 Heat exchanger
- 15 Safety/drain valve
- 16 Water pressure reducer



## Function description

The Combi D diesel heater is a warm-air heater with integrated hot water boiler (10 litres volume). The burner operates fan-supported, which ensures trouble-free function even when on the move.

In **winter operation** the heater can be used to heat the room and simultaneously warm water. If only warm water is required, select **summer operation**.

- In **summer operation**, the water contents are heated in the smallest burner stage. Once the water temperature is reached, the burner switches off.
- In **winter operation**, the unit automatically selects the required power setting according to the temperature difference between the temperature set on the control panel and the current room temperature. When the boiler is filled, the water is automatically heated as well. The water temperature depends on the selected operational mode and the heater output.

An additional altitude kit (part no. 34610-01) is required for long periods of heater operation at altitudes of 1500 to 2750 m.

## Safety instructions

In the event of a leak in the heater or the exhaust duct:

- use the rotary switch to switch off heater,
- open windows and door,
- ask an expert to inspect the entire system!



Repairs may only be carried out by an expert!

Guarantee claims, warranty claims and acceptance of liability will be ruled out in the event of the following:

- modifications to the unit (including accessories),
- modifications to the exhaust duct and the cowl,
- failure to use original Truma parts as replacement parts and accessories,
- failure to follow the installation and operating instructions.

It also becomes illegal to use the appliance, and in some countries this even makes it illegal to use the vehicle.

During the initial operation of a brand new appliance (or after it has not been used for some time), a slight amount of fumes and smell may be noticed for a short while. It is a good idea to heat the device up several times in summer operation (60 °C) and to make sure that the area is well ventilated.

The system must comply with the respective regulations of the country in which it is used. National regulations and rules must be followed.

Do not place articles on or against this appliance.

Do not use or store flammable materials near this appliance.

Do not spray aerosols in the vicinity of this appliance while it is in operation.

The exhaust system must be inspected by a qualified technician at regular intervals, not exceeding two years.

No work must be carried out on the heater, the exhaust duct or in the vicinity of the chimney while the unit is in operation.

Do not inhale exhaust fumes.

Before performing any work on the heater or the exhaust duct, switch off the heater and allow all parts to cool completely.

The heater must not be used during fuelling, or in enclosed car parks, in garages, or on ferries.

Do not operate the heater anywhere where flammable vapours or dust can form, e.g. in the vicinity of a fuel, carbon, wood or cereal storage facility or similar.

## Important operating notes

If the cowl has been placed near or directly beneath an opening window, the device must be equipped with an automatic shut-off device in order to prevent operation with the window open.

The exhaust gas double duct (exhaust gas silencer and suction pipe) must be inspected regularly, particularly following long journeys, to check for any damage and to ensure that the connection is sound; the same applies to the mounting of the heater and the cowl.

The cowl and the combustion air infeed must be kept free of dirt (e.g. snow sludge, ice, foliage, etc.) at all times.

The hot air outlets and circulating / exhaust air intake openings must be unobstructed, to ensure that the heater is not at risk of overheating. The built-in temperature limiter blocks off the fuel supply when the heater becomes excessively hot.

Even outside the season, the heater should be operated once a month for about ten minutes.



When operational, the fuel display in the fuel tank must not be allowed to drop to the "low fuel" mark.

In the event that the vehicle fuel tank runs empty, the opening of the fuel removal duct is roughly at the same height as the surface of the fuel. In this state, and in particular when the fuel in the vehicle fuel tank slops around due to vehicle movement, a large amount of air is sucked in. This leads to an irregular supply of fuel to the heater. The heater burner is unable to maintain clean combustion in this condition, leading to the formation of smoke and odours.

A diesel heating system always needs more power than a similar gas heating system. If there is a requirement for an autarky of the same length (service life without external power supply), Truma recommends investigating whether it is possible to retrofit a larger and / or second battery.

If fitting an isolation switch the switch must be installed in such a position that the heater can not be switched off unintentionally. The heater must always be turned off at the heater control. The 12 V isolation switch should only be used after the heater has completed its cool down cycle and has stopped completely.

## Fuel supply / quality

The heater requires diesel fuel, as per the Australian Fuel Standard (Automotive Diesel). Operation with any form of biodiesel is not permitted.

## Operating instructions

**Always observe the operating instructions and “Important operating notes” prior to starting!** The vehicle owner is responsible for the correct operation of the appliance.

The installer or vehicle owner must apply the yellow sticker with the warning information, which is enclosed with the appliance, to a place in the vehicle where it is clearly visible to all users (e.g. on the wardrobe door)! Ask Truma to send you stickers, if necessary.

**i** Before using for the first time, it is essential to flush the entire water supply system through with clean water. If the heater is not being used, always drain the water contents if there is a risk of frost! **There shall be no claims under guarantee for damage caused by frost!**

**i** Materials in the device which come into contact with water are suitable for use with drinking water (see manufacturer declaration: [www.truma.com](http://www.truma.com) – Downloads – Manufacturer Declaration).

## Control panel

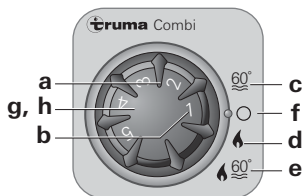

- a = Rotary switch for room temperature (1 – 5)
- b = green LED lit “Operation”  
green LED blinking  
“after-running” is active in order to reduce the unit’s temperature
- c = Summer operation (water temperature 60 °C)
- d = Winter operation  
(heating **without** water temperature monitoring  
or with drained water system)
- e = Winter operation  
(heating **with** water temperature monitoring)
- f = Rotary “Off” switch
- g = yellow LED lit “Boiler heat-up phase”  
yellow LED flashes “failure”
- h = red LED lit, red LED blinking “failure”

**i** The LEDs are visible only when the unit is switched on.

## Room thermostat

To measure the room temperature, an external room temperature sensor (i) is located in the vehicle. The location of the sensor is determined individually by the vehicle manufacturer, depending on the vehicle type; consult the operating instructions for your vehicle for further details.

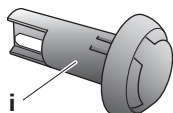

i = Room temperature sensor

The thermostat setting on the control panel (1 – 5) must be determined individually depending on the heating requirement and the type of vehicle. For an average room temperature of about 23 °C, we recommend a thermostat setting of about 4.

## Initial start-up

(or when the fuel tank has run empty)

### Filling the fuel lines

The heater normally has to be started up several times to fill the fuel lines.

Connect unit to control panel to do this. The unit automatically performs 2 start attempts (initial start and repeat) per switch-on procedure with a run time of 2 minutes in each case. If no flame is detected after the repeat start, the unit switches to fault and has to be switched off and on again at the control panel.

**i** After a total of 15 unsuccessful starting attempts (initial and repeat start) without forming a flame, the equipment is blocked. To remove the block, please contact the Dometic Service Centre (see Service Booklet or [www.truma.com](http://www.truma.com)).

Check fuel lines and connections for leaks after filling the fuel lines.

## Taking into operation

**i** Heating operation is basically possible without restriction with or without water content.

Check to make sure the cowl is unobstructed. Remove any covers that may be present.

## Summer operation

(boiler operation only)

Move the rotary switch on the control panel to position (c – summer operation) 60 °C. The green (b) and yellow (g) LEDs light up.

After reaching the set water temperature (60 °C), the burner will switch off and the yellow LED (g) will be extinguished.

## Winter operation

– Heating **with** water temperature monitoring

Set the rotary switch to the operational setting “e”.

Set the rotary switch (a) to the desired thermostat setting (1 – 5). The green LED (b) for operation is lit and simultaneously indicates the position of the selected room temperature. The yellow LED (g) indicates the water’s heat-up phase.

The unit automatically selects the required power level according to the temperature difference between the setting on the control panel and the current room temperature. Once the room temperature set on the control panel has been reached, the burner switches back to the lowest stage, and heats the water content to 60 °C. The yellow LED (g) will be extinguished after the water temperature is reached.

The warm air fan can continue to run in order to cool the unit (after-run).

– Heating **without** water temperature monitoring

Set the rotary switch to the operational setting “d”.

Turn the rotary switch (a) to the desired thermostat setting (1 – 5). The green LED (b) for operation is lit and simultaneously indicates the position of the selected room temperature. The yellow LED (g – water’s heat-up phase) will be lit only when the water temperature is below 5 °C!

The unit automatically selects the required power level according to the temperature difference between the setting on the control panel and the current room temperature. After reaching the room temperature set on the control panel, the burner will switch off. The warm-air fan will continue to run at a low speed as long as the blow-out temperature (on the unit) is higher than 40 °C.

If the boiler is filled, the water will automatically be heated at the same time. The water temperature is then dependent on the heating output being given off, and the duration of heating required to reach the desired room temperature.

– Heating with **drained** water system

Set the rotary switch to the operational setting “d”.

Turn the rotary switch (a) to the desired thermostat setting (1 – 5). The green LED (b) for operation is lit and simultaneously indicates the position of the selected room temperature. The yellow LED (g) will be lit only when the temperature of the unit is below 5 °C!

The unit automatically selects the required power level according to the temperature difference between the setting on the control panel and the current room temperature. After reaching the room temperature set on the control panel, the burner will switch off.

## Switching off

Use the rotary switch to switch off heater (position f). The green LED (b) goes off.

**i** If the green LED (b) blinks after switching off, then the unit’s after-running is active in order to reduce the unit’s temperature. This will end after a few minutes and the green LED (b) will go off.

**Always drain water contents if there is a risk of frost!**

## Red / yellow LED “failure”

A failure is indicated when the red LED (h) shines or when the red (h) or yellow LED (g) flashes.

Please consult the Trouble-Shooting list for possible causes.

A reset (fault reset) is carried out by switching off, waiting until all LED’s on the control panel have stopped flashing, and then switching the heater on again.

**i** If the window, to which a window switch is mounted, is opened, the heating device stops operating and the yellow LED (g) flashes 3 times. The heater continues operating when the window is closed.

## Filling the water heater

Check that the drain valve in the cold water intake is closed: Lever should be in horizontal position, position (k).

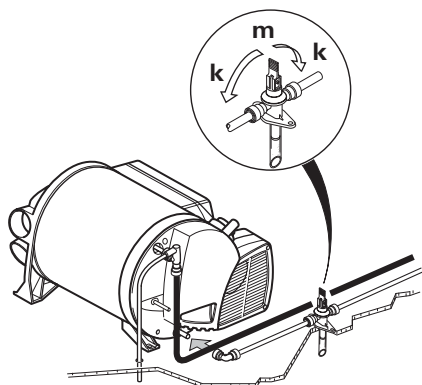

k = Lever position “Closed”  
m = Lever position “Drain”

Switch on the power for the water pump (either by the main switch or the pump switch).

Open hot water taps in kitchen and bathroom, (set preselecting mixing taps or single-lever fittings to “hot”). Leave the fittings open for as long as it takes for the boiler to displace the air and fill up, and the water to flow without interruption.

**i** If only the cold water system is operated, without the boiler, the boiler still fills with water. To avoid frost damage, the boiler must be drained through the drain valve, even if it was not operated.

**!** When connecting to a central water supply (rural or city mains), a pressure reduction valve must always be installed to prevent pressures above 2.8 bar from developing in the water heater.

## Draining the water heater

Switch off the power for the water pump (either by the main switch or the pump switch).

Open hot water taps in kitchen and bathroom.

Open safety/drain valve: Lever in vertical position, position (m).

The boiler is now drained directly to the outside via the drain valve. Place a bucket beneath the outlet to check whether the water content has completely drained away (10 litres). **There shall be no claims under guarantee for damage caused by frost!**

## Maintenance

Only original Truma parts may be used for maintenance and repair work.

Clean installation area at least once per year, and have unit checked for soiling and cleaned by an expert if necessary.

Biofilm, deposits and limescale must be removed using chemicals to protect the unit from infestation by microorganisms. Only chloride-free products must be used in order to prevent damage to the unit.

The effectiveness of the use of chemicals to combat microorganisms in the unit can be increased by heating the water in the boiler to 70 °C at regular intervals.

To do this, turn the rotary switch on the control panel to the 60 °C (c – summer mode) position. The green (b) and yellow (g) LEDs light up.

**i** Once the water in the boiler has reached a temperature of 60 °C, the burner will switch off and the yellow LED (g) will go out. The unit must stay switched on for at least 30 minutes and no warm water may be removed. The residual heat in the heat exchanger will heat the water up to 70 °C.

## Fuses

The fuses are located in the electronic control unit, beneath the connector cover. When replacing a fuse, be sure to use the same type.

Device fuse: 10 A – slow – (T 10 A)

Burner fuse: 20 A – slow – 6.3 x 32 mm

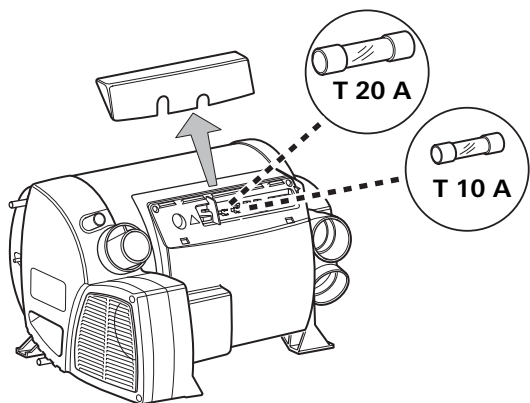

## Disposal

The heater unit must be disposed of in accordance with the administrative regulations of the country in which it is in use. National regulations and laws must be observed.

## Technical data

found by Truma Test conditions

### Fuel

Fuel, as per the Australian Fuel Standard (Automotive Diesel). Operation with any form of biodiesel is not permitted.

### Water contents

10 litres

### Heating up time from approx. 15 °C to approx. 60 °C

Boiler approx. 20 minutes (measured according to EN 15033)

Heater + boiler approx. 80 min.

### Water pressure

max. 280 kPa

### Rated thermal output (automatic output levels)

2000 / 4000 / 6000 W

### Fuel consumption

220 – 630 ml/h (in regular operation, between "Off" and "lowest operating level" less than 190 ml/h).

### Air delivery volume (free-blowing without hot-air pipe)

max. 287 m<sup>3</sup>/h

### Current input at 12 V

Heater + boiler 1.8 – 7 A (in regular operation, between "Off" and "lowest operating level" less than 1.8 A).

Heating boiler without operational heater, max. 1.8 A

Stand-by: approx. 0.001 A

### Weight (not containing water)

Heater unit: 15.8 kg

Heater unit with peripheral devices: 17.2 kg

### Declaration of conformity

The heater complies with heater directive 2001/56/EC and supplements 2004/78/EC and 2006/119/EC and bears the type approval number: e1 00 0232

The heater complies with the interference suppression directive 72/245/EEC for vehicle engines with annexes 2004/104/EC, 2005/83/EC and 2006/28/EC and bears type approval number: e1 03 5277

The heater complies with low voltage directive 73/23/EEC.



## Dimensions

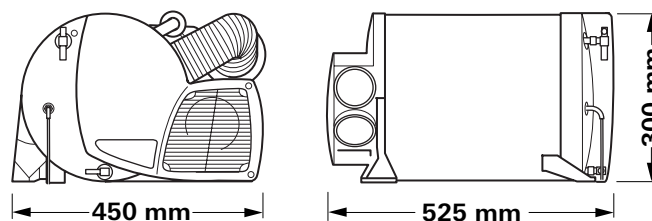

The right to effect technical modifications is reserved!

## Trouble-shooting list

Flash code on the control panel

Flash sequence LED:

– On: 0.5 seconds

– Off: 0.5 seconds

Pause between the flashing sequence: 3 seconds

Fault	Cause	Rectification
After switching on (winter and summer operation) none of the LEDs are lit.	<ul style="list-style-type: none"> <li>– No operating voltage.</li> <li>– Device fuse or vehicle fuse defective.</li> </ul>	<ul style="list-style-type: none"> <li>– Check 12 V battery voltage, charge if necessary.</li> <li>– Check all electrical plug connections.</li> <li>– Check the unit or vehicle fuse and replace if necessary (see fuses).</li> </ul>
The green LED comes on when the unit is switched on, but the heater does not operate.	<ul style="list-style-type: none"> <li>– The temperature setting on the control panel is lower than the room temperature.</li> </ul>	<ul style="list-style-type: none"> <li>– Select higher room temperature at the control panel.</li> </ul>
Green LED flashes after heater is switched off.	<ul style="list-style-type: none"> <li>– After-running is active in order to reduce the unit's temperature.</li> </ul>	<ul style="list-style-type: none"> <li>– No error. Coasting operation switches off after max. 5 minutes.</li> </ul>
Red LED flashes 6 x.	<ul style="list-style-type: none"> <li>– Insufficient fuel due to insufficient fuelling, empty tank, and / or inclined vehicle orientation.</li> </ul>	<ul style="list-style-type: none"> <li>– Fill tank with fuel. Then fill the fuel line as described under "Initial start-up".</li> </ul>
Red LED flashes (except 6 times) or red LED shines.	<ul style="list-style-type: none"> <li>– Malfunction of the heating device.</li> </ul>	<ul style="list-style-type: none"> <li>– Please contact the Dometic Service.</li> </ul>
Yellow LED flashes 1 x.	<ul style="list-style-type: none"> <li>– Possible under-voltage &lt; 11.5 V.</li> </ul>	<ul style="list-style-type: none"> <li>– Use the electrical power from the battery carefully, e.g. restrict lighting.</li> <li>– Charge battery.</li> </ul>
Yellow LED flashes 2 x.	<ul style="list-style-type: none"> <li>– Under-voltage &lt; 10.2 V.</li> <li>– Over-voltage &gt; 15.8 V.</li> </ul>	<ul style="list-style-type: none"> <li>– Check battery voltage, charge if necessary.</li> <li>– Short-term immediate measure: switch off heavy load or start up vehicle engine until the heater starts running (approx. 4 minutes).</li> <li>– Battery capacity inadequate, if necessary exchange old battery.</li> <li>– Check the battery voltage and power supply such as e.g. the charging device.</li> </ul>
Yellow LED flashes 3 x.	<ul style="list-style-type: none"> <li>– Open window above cowl (window switch).</li> </ul>	<ul style="list-style-type: none"> <li>– Close window.</li> </ul>
Yellow LED flashes 4 x.	<ul style="list-style-type: none"> <li>– Warm air temperature and / or water temperature exceeded: <ul style="list-style-type: none"> <li>– Not all warm air ducts are connected.</li> <li>– Hot-air outlets blocked.</li> <li>– Recirculated air intake blocked.</li> </ul> </li> <li>– Summer operation with empty water tank.</li> </ul>	<ul style="list-style-type: none"> <li>– Check whether the 4 warm air ducts are connected.</li> <li>– Check individual outlet apertures.</li> <li>– Remove blockage from recirculated air intake.</li> <li>– Fill boiler with water.</li> </ul>
Yellow LED flashes 5 x.	<ul style="list-style-type: none"> <li>– Room temperature sensor or cable defective.</li> </ul>	<ul style="list-style-type: none"> <li>– Please contact the Dometic Service.</li> </ul>
Yellow LED flashes 7 x.	<ul style="list-style-type: none"> <li>– Control panel or control panel cable defective.</li> </ul>	<ul style="list-style-type: none"> <li>– Please contact the Dometic Service.</li> </ul>



Fault	Cause	Rectification
-------	-------	---------------

### Water supply

Water running out, cannot fill boiler.	– Safety/drain valve open.	– Close safety/drain valve.
Cannot empty boiler, even though safety/drain valve is open.	– Safety/drain valve draining connection blocked.	– Check opening for soiling (slush, ice, leaves etc.) and remove if necessary.
Water dripping from draining connection of safety/drain valve.	– Water pressure too high.	– Check pump pressure (max. 400 kPa). If connected to a central water supply (rural or urban connection), a pressure reducer must be used, which will prevent pressures higher than 280 kPa entering the boiler.
When opening the cold water tap, hot water comes out.	– Hot water flows back through the cold water supply.	– Fit a no-return valve in the cold water supply (refer to installation instructions “Water connection”).

**If these measures do not remove the failure, please contact the nearest Dometic Service.**



## Accessories

Truma Timer ZUCB complete with 3 m connecting cable (part no. 34043-01). 6 m extension cable for time switch ZUCB (part no. 34301-03).



As standard, Truma supplies a suitable cover frame, in agate grey colour, for every control panel / every time switch.

Line-up clip, 1 unit (part no. 34000-65900).  
For installing several Truma control panels next to each other.

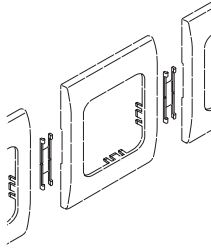

Other accessories (without picture) for control panel:

- 6 m control panel cable (part no. 34020-21400)
- coupling (part no. 34020-21500)
- 3 m extension cable, including coupling (part no. 34301-02)
- 6 m extension cable, including coupling (part no. 34301-01)

## Truma warranty policy

The warranty is given by Dometic Pty Ltd, 6 Treforest Drive, Clayton, Victoria 3168, for 12 months from the date of purchase against any defect arising from faulty materials or workmanship.

Repairs will be carried out during normal business hours only by Dometic Pty Ltd, or its duly authorised service agents, and are subject to the warranty conditions and exclusions hereunder.

### Warranty conditions

- The company will only provide service on presentation of proof of purchase, on either the Truma product, or the Caravan / RV / Pleasure Craft in which the Truma product has been installed, to any authorised service agent. The purchaser must allow the service agent to photocopy the proof of purchase to facilitate his claim to the manufacturer.
- Warranty repairs can only be performed by authorised service agents and under no circumstances will Dometic reimburse repairs carried out by unauthorised persons. Tampering with any part of the product by unauthorised personnel will automatically void the warranty.
- The product must be used solely for domestic purposes only. If the product is used for commercial purposes the warranty is 6 months only.
- Where applicable, the products must be used on the appropriate electrical voltage, gas type and pressure, or fuel source.
- If at any time during the warranty period any part or parts are replaced with a part or parts not supplied or approved by Truma, this warranty shall immediately become void.

### Important notice

Before calling a service technician please check carefully the operating instructions, service booklet and warranty terms and conditions. If the product fails for any of the reasons detailed therein, or is faulty due to abuse, misuse or improper installation, then a service fee shall be charged to the purchaser.

If you have any queries regarding the interpretation of the warranty you should contact Dometic Pty Ltd.

Whilst this book represents service outlets at the time of printing, changes occur from time to time. Should you have any queries or wish to locate your nearest authorised service agent please contact Dometic Pty Ltd.

### Warranty does not cover

- Any heater which has been:
  - (a) Subject to misuse, neglect, accident or alteration by any person.
  - (b) Damaged or destroyed by fire, flood, act of God or other inevitable accident.
- Fair wear and tear.
- Damage from foreign substances such as dirt or liquid.
- Travelling expenses or call out fee to and from authorised service agents premises.
- Accommodation or Site Expenses.
- Cleaning of the system. This is considered to be a part of normal product maintenance.
- Non operation of the heater or resultant damage to the unit where the heater has been operated in an out of level situation.
- Freight cost of the appliance or parts, to or from, point of service or transit damage.
- Dometic / Truma are not responsible for resultant loss or damage sustained by the purchaser.
- Non operation of the appliance or resultant damage to the unit where the appliance has not been installed, ventilated, flued or operated in accordance with the manufacturers instructions.

Apart from any warranties implied by the Trade Practices Act 1974 or any relevant State legislation all other warranties express or implied whether arising by virtue of statute or otherwise are hereby excluded.



## Combi D 6 (Australia)



